

alarm

VIBRATION DETECTION MODULE

The V-ALARM module is a vibration detection module. It can be used in standalone mode (no security system required. Connect a siren for example) or connected with an existing security system. It has flexible configuration options and offers itself to various applications.

PART NUMBER	DESCRIPTION
V-ALARM-1-STD	Standard VALARM unit
V-ALARM-1-GRM	For use with GALARM system

Table 1 Ordering options

| APPLICATIONS

Gate monitoring (including swing gates) to detect gate tamper, gate motor tampering and theft

Home Security gates

Solar panel monitoring

Garage door monitoring

Caravan and boat monitoring

Power Distribution Boxes

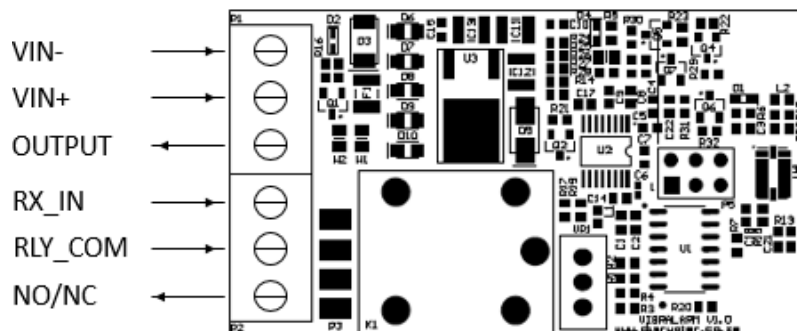

Figure 1 - V-ALARM inputs and outputs

| REQUIREMENTS (Application dependent)

10-16V DC input supply

A NON-Integrated RF receiver with trigger LOW (Ground) when remote is pressed (for remote control applications). Can be used with your current gate motor RF Receiver as long as it is not an onboard or integrated receiver. Or you could use an optional separate receiver. Sherlotronics RX1-150 or similar suggested.

(Optional) TX transmitter with trigger LOW (Ground) to transmit to alarm (Sherlotronics S1 or similar suggested)

(Optional) Alarm system (wired NC contact like alarm PIR sensor or beam).

| INSTALLATION PROCEDURE

Wire the PCB as per below instructions

Use double-sided tape to stick PCB to inside of enclosure

Use double-sided tape to stick PCB to unit to monitor (ie on gatemotor motor or controller, on garage door frame, on security gate frame, underneath solar panel). Use Sikaflex FC11 for more permanent installations in challenging environments.

Test the VALARM sensitivity. The STATUS LED will flash every 3-4 seconds in standby mode. Once a tamper/vibration is detected, the STATUS LED will stay LIT while vibration is occurring.

The VALARM is shipped with a default sensitivity setting, which is sufficient for most monitoring applications.

If required, adjust sensitivity with small screwdriver as required (clockwise for less sensitivity)

Shake gate or garage door, to ensure device triggers

Close lid on VLARM unit, and replace four (4) screws

| FUNCTIONAL DESCRIPTION

Table 1 shows the functional purpose of each connection on the V-ALARM module.

INPUT/OUTPUT	DESCRIPTION
VIN-	Negative input of power supply
VIN+	Positive input of power supply
OUTPUT	TRIGGER output, open collector, active LOW
RX_IN	Input from RX receiver (active LOW when remote press)
RLY_COM	Relay COM connection
NO/NC	NO/NC relay connection (Selectable with W1/W2)

Table 1 - INPUT/OUTPUT Description

On power-up, the STATUS_LED will flash two (2) times. The STATUS_LED will then flash ONCE every few seconds, indicating the unit is RUNNING in STANDBY mode.

The vibration THRESHOLD can be adjusted on the POTENTIOMETER (TRIMMER) during installation. Once the vibration THRESHOLD is exceeded, the STATUS_LED will switch ON, and an alarm condition will trigger. During an alarm condition, the RELAY output will activate.

The OUTPUT will switch ON (pull to GND) and OFF twice during this time. The STATUS_LED will indicate the alarm condition, as per Table 3.

Once the SIREN TIME (30 seconds) has expired, the RELAY output will switch OFF. The STATUS_LED will return to the STANDBY condition

The STATUS_LED will then indicate the unit STATUS following the event, as per Table 2.

When the input voltage drops below 10V in standby mode, an alarm condition will also trigger. This is to ensure that the voltage is sufficient for typical RF transmitters used to link to alarm system. This option can be disabled if required. Contact us for information on disabling this feature.

STATUS LED	DESCRIPTION
FLASH x1	Running in STANDBY mode
FLASH x2	Vibration Trigger
FLASH x3	Low-voltage trigger
FLASH x4	Gate-open authorized

Table 2 - STATUS_LED operation

| V-ALARM integration

When the V-ALARM module is used in standalone mode, it can be connected to a siren, alarm RF transmitter and/or alarm system (through Relay NO/NC connection)

| GATE MONITORING

The RX_IN input can be connected to the gate motor Receiver. When a paired remote is pressed (causing the gate to open when the Receiver pulls LOW (to GND)), the V-ALARM will acknowledge authorized opening of the gate, and NOT TRIGGER an alarm condition. The V-ALARM will ignore any alarm condition for two (2) minutes while the gate open and close. Pressing the paired remote again will restart the two (2) minute counter every time it is pressed.

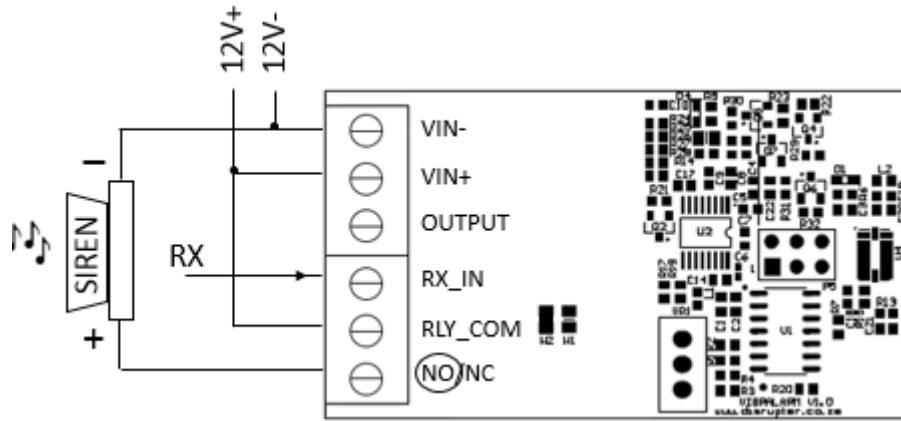

Figure 2 - Standalone mode with siren (and RX input from gate motor)

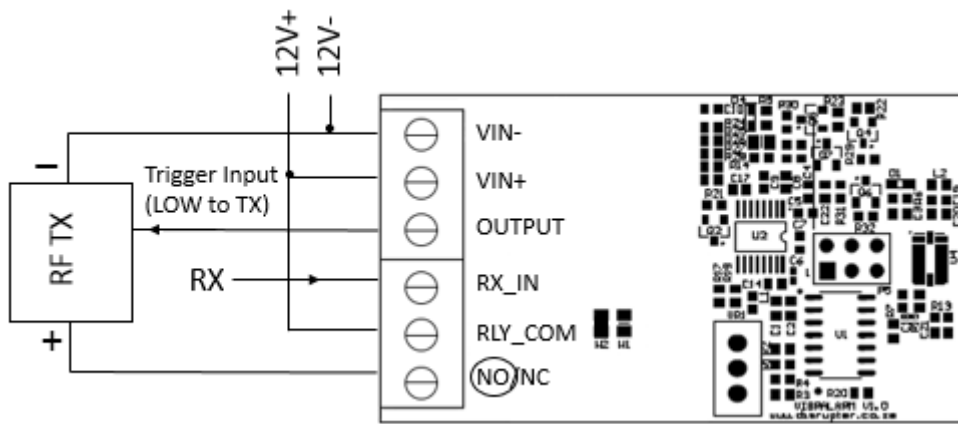

Figure 3 - Low-power connection of RF Transmitter only

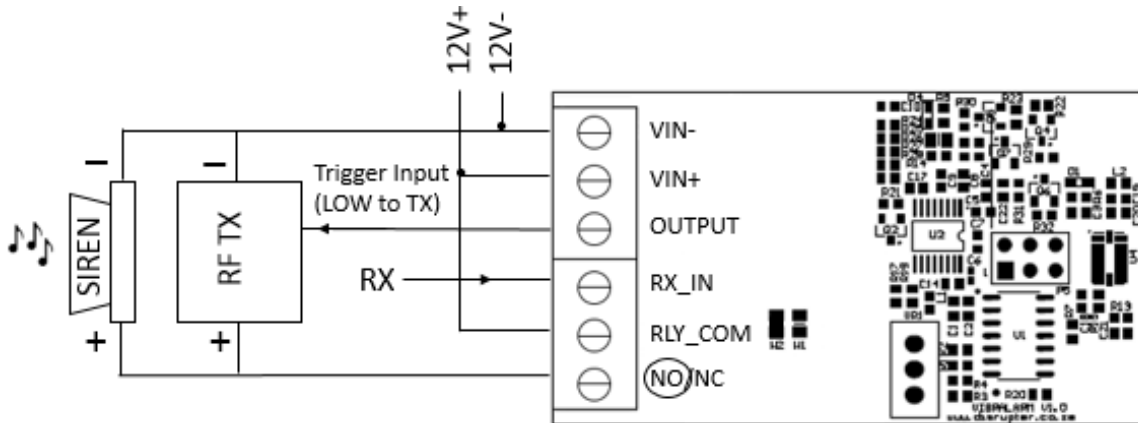

Figure 4 - Low-power connection of RF Transmitter and siren

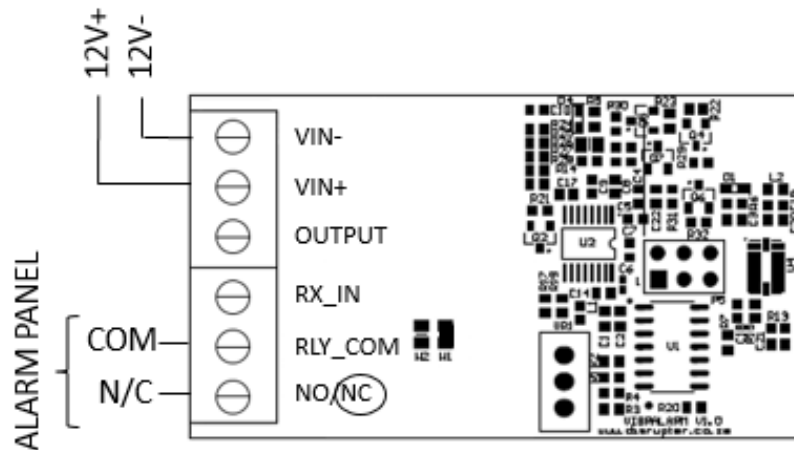

Figure 5 - Relay connection to existing alarm system

The RELAY contact can be set to NO (Normally-open) or NC (Normally-closed), by soldering the W1 (NC) or W2 (NO) link. NOTE only the applicable link should be soldered.

The VALARM module has a current consumption of +-1mA in STANDBY mode (no vibration detected). It can be used in applications where only a battery, such as a 12V 7Ah SLA battery is available. The unit will run for several months before the battery will need to be recharged. This makes the product ideal for standalone implementations in remote areas, warehouses, farms, plots or sites.

For technical support, please contact your VALARM dealer, or contact us at info@disrupter.co.za

View the FAQ on our website for typical questions answered.

Also view the VALARM video on Youtube on DisrupterSA.

It is good practice to test any security system frequently, to ensure satisfactory and reliable operation, and ultimately ensuring your safety. The same is recommended for the VALARM product.

DISRUPTER

TECHNOLOGIES

www.disrupter.co.za